

Pufferspeicher
Buffer storage tanks
Ballon tampon
Accumulatori tampone
PSR 500 – 600

EnEV 730.02
ErP 812/2013
ErP 814/2013
CE

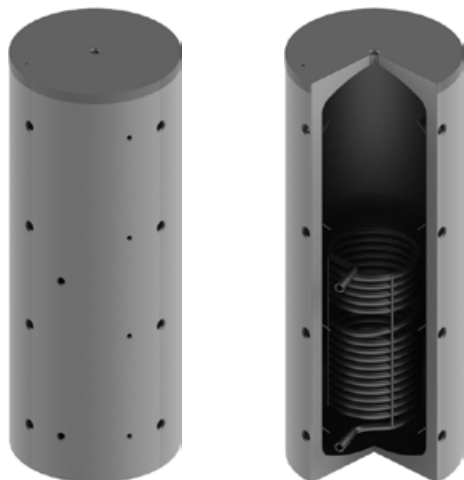

Bauart
Design | Structure | Struttura

Die Speicher werden aus hochwertigem Stahl nach EN 10025 gefertigt.

EN The storage tanks are made from high quality steel in accordance with EN 10025.

FR Les ballons sont fabriqués en acier de grande qualité, selon la norme EN 10025.

IT Gli accumulatori sono realizzati in acciaio pregiato secondo la norma EN 10025.

Betriebsdruck / Prüfdruck Operating pressure / test pressure Pression de service / Pression test Pressione d'esercizio / Pressione di collaudo	3 bar / 4.5 bar
Einsatzgebiet Application Application Applicazione	18°C – 95°C

Lieferumfang
Delivery | Livraison | Consegna

Bedienungsanleitung Operation manual Mode d'emploi Istruzioni per l'uso	1 x
---	-----



Schutz vor Korrosion

Anti-corrosion protection | Protection contre la corrosion | Protezione anticorrosiva

Innen sind die Speicher unbehandelt. Aussen sind die Speicher mit PU-Schaum fix geschäumt.

EN The storage tanks are untreated on the interior. On the exterior the storage tanks are foamed with polyurethane foam.

FR À l'intérieur, les réservoirs ne sont pas traités. À l'extérieur, ils sont recouverts de mousse fixe.

IT L'interno degli accumulatori non è trattato. All'esterno gli accumulatori presentano una copertura di schiuma PU fissa.

Wärmetauscher

Heat exchanger | Échangeur de chaleur | Scambiatore di calore

Ein eingeschweisster grossflächiger Wärmetauscher.

EN One welded large-surface heat exchanger.

FR Un échangeur de chaleur grande surface soudé.

IT Uno scambiatore di calore saldato di grande superficie.

Isolierung

Insulation | Isolation | Isolamento

PU-Hartschaum

60 mm PU-Hartschaum fix geschäumt. Skaimantel 5 mm mit Reissverschluss vormontiert, inklusive Rosetten und Abdeckhaube. Brandschutzklasse B2. Silber. Weitere Farben nach Absprache.

EN Rigid polyurethane foam
60 mm rigid polyurethane foam. Skai jacket 5 mm with zip preassembled, including cover plates and hood. Fire-resistance rating B2. Silver. Other colours on request.

FR Mousse solidifiée PU
60 mm de mousse dure PU Enveloppe en skai de 5 mm préinstallée avec fermeture à glissière, y compris rosettes et capot. Classe allemande de protection incendie B2. Argent. Autres couleurs après concertation.

IT Schiuma PU rigida
60 mm di schiuma rigida di poliuretano fissa. Mantello in skai da 5 mm pre-assemblato con cerniera, dotato di rosette e calotta di copertura. Classe di resistenza antincendio B2. Argento. Altri colori su richiesta.

≤ 600 L
PU-Hartschaum

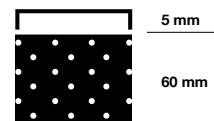

5 mm

60 mm

Pufferspeicher
Buffer storage tanks
Ballon tampon
Accumulatori tampone
PSR 500 – 600



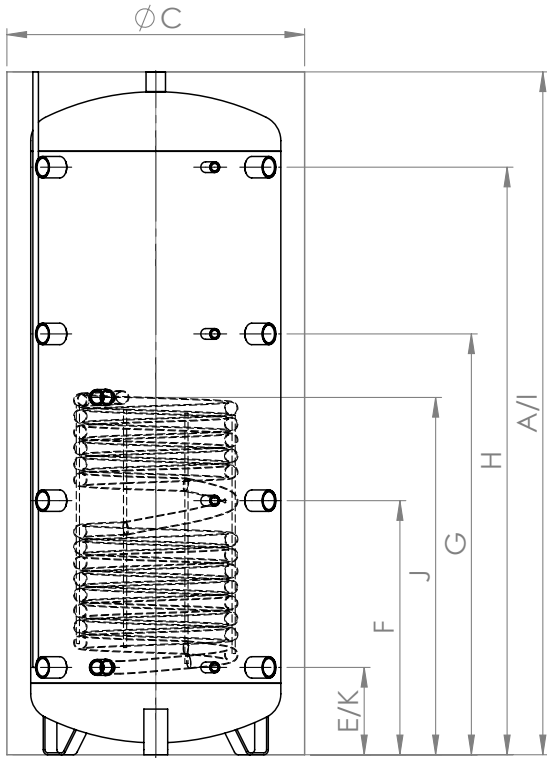



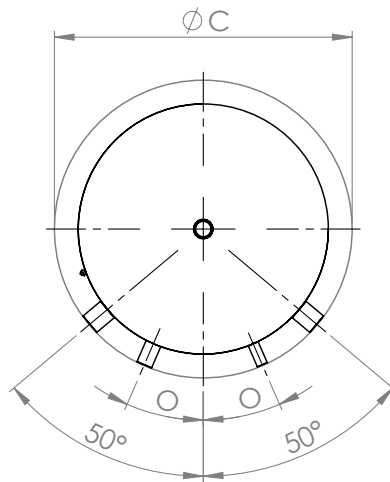



500 – 600



300 – 600



300 – 600

	Verwendung Usage Utilisation Uso	Dimension Dimension Dimension Dimensione	500	600
	Inhalt Capacity Contenance Contenuto	l	479	559
	Glattrohrwärmetauscher Heating coil Échangeurs de chaleur Serpentino	m ²	1.8	2.2
		l	11.8	14.2
	Kippmass Tilted dimension Cote de basculement Altezza in raddrizzamento	mm	1880	2120
A	Höhe mit Isolierung Height with insulation Hauteur avec isolation Altezza con isolamento	mm	1720	1980
C	Ø mit Isolierung with insulation avec isolation con isolamento	mm	750	750
E*	Anschluss 1 Connection Raccord Collegamento	 – mm	220	220
		G"	1 ½"	1 ½"
		 – G"	½"	½"
F*	Anschluss 2 Connection Raccord Collegamento	 – mm	640	730
		G"	1 ½"	1 ½"
		 – G"	½"	½"
G*	Anschluss 3 Connection Raccord Collegamento	 – mm	1060	1230
		G"	1 ½"	1 ½"
		 – G"	½"	½"
H*	Anschluss 4 Connection Raccord Collegamento	 – mm	1480	1740
		G"	1 ½"	1 ½"
		 – G"	½"	½"
I	Anschluss oben Connection above Raccord du haut Collegamento superiore	 – mm	1720	1980
		G"	1 ¼"	1 ¼"
J	VL Glattrohrwärmetauscher Heating coil Échangeurs de chaleur Serpentino	 – mm	900	1010
		G"	1"	1"
K	RL Glattrohrwärmetauscher Heating coil Échangeurs de chaleur Serpentino	 – mm	220	220
		G"	1"	1"
O	Anordnung Fühler Positioning sensor Disposition sonde Disposizione sensore	°	23.5	23.5
Isolierung Insulation Isolation Isolamento			60 mm fix eingeschäumt Fixed with foam Enravage mousse fixe Schiuma rigida fissa	
	Wärmeverlust Heat losses Pertes thermiques Perdita di calore	kWh/24h	1.89	2.03
	ErP-Klasse ErP class Classe ErP Classe ErP		B	B
	Gewicht Weight Poids Peso	kg	101	125
	Art.Nr. 200105... Part no. Réf. Art.n.		0500	0600
	Elektroheizung zum Einschrauben* Screw-in Immersion heater* Résistances à visser* Resistenza elettrica da avvitare*	bis kW to à a	6.0	7.5

*Einbaumöglichkeit: 1 x Elektroheizung zum Einschrauben
Installation option: 1 x Screw-in Immersion heater | Option d'installation: 1 x Résistances à visser | Opzione di installazione: 1 x Resistenza elettrica da avvitare

Pufferspeicher
Buffer storage tanks
Ballon tampon
Accumulatori tampone
PSR 500 – 5000

EnEV 730.02
ErP 812/2013
ErP 814/2013
CE

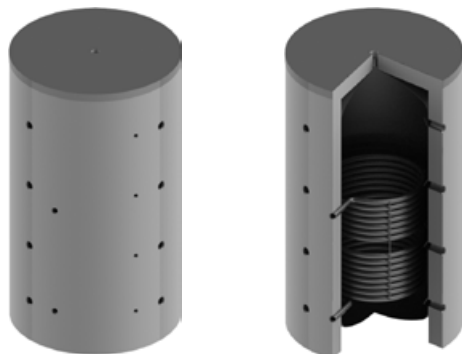

Bauart
Design | Structure | Struttura

Die Speicher werden aus hochwertigem Stahl nach EN 10025 gefertigt.

EN The storage tanks are made from high quality steel in accordance with EN 10025.

FR Les ballons sont fabriqués en acier de grande qualité, selon la norme EN 10025.

IT Gli accumulatori sono realizzati in acciaio pregiato secondo la norma EN 10025.

Betriebsdruck / Prüfdruck Operating pressure / test pressure Pression de service / Pression test Pressione d'esercizio / Pressione di collaudo	3 bar / 4.5 bar
Einsatzgebiet Application Application Applicazione	18°C – 95°C

Lieferumfang
Delivery | Livraison | Consegna

Bedienungsanleitung Operation manual Mode d'emploi Istruzioni per l'uso	1 x
---	-----

Schutz vor Korrosion
Anti-corrosion protection | Protection contre la corrosion | Protezione anticorrosiva

Innen sind die Speicher unbehandelt. Aussen sind die Speicher mit einem Antikorrosionslack lackiert.

EN The storage tanks are untreated on the interior. The storage tanks are externally coated with a corrosion-protection paint.

FR À l'intérieur, les réservoirs ne sont pas traités. À l'extérieur, les réservoirs sont recouverts d'une laque anticorrosion.

IT L'interno degli accumulatori non è trattato. Gli accumulatori sono verniciati all'esterno con uno smalto resistente alla corrosione.

Wärmetauscher
Heat exchanger | Échangeur de chaleur | Scambiatore di calore

Ein eingeschweisster grossflächiger Wärmetauscher.

EN One welded large-surface heat exchanger.

FR Un échangeur de chaleur grande surface soudé.

IT Uno scambiatore di calore saldato di grande superficie.



Isolierung

Insulation | Isolation | Isolamento

TopShell

Isolierung aus Hightech Faservlies. Skaimantel mit Reißverschluss, inklusive Rosetten und Abdeckhaube. Brandschutzklasse B2. Silber. Lose geliefert.

Variante

Isolierung aus Hightech Faservlies. PS-Mantel und Hakenleiste, inklusive Rosetten und Abdeckhaube. Brandschutzklasse B2. Farbe Silber.

EN TopShell

Insulation made of high-tech fibre fleece. Skai jacket with zip, including cover plates and hood. Fire-resistance rating B2. Silver. Supplied loose.

FR TopShell

Isolation en tissu fibreux high-tech Enveloppe en skai avec fermeture à glissière, y compris rosettes et capot. Classe allemande de protection incendie B2. Argent. Livrée non montée.

IT TopShell

Isolamento in tessuto non tessuto high-tech. Mantello in skai pre-assemblato con cerniera, dotato di rosette e calotta di copertura. Classe di resistenza antincendio B2. Argento. Consegna sfusa.

Alternative

Insulation made of high-tech fibre fleece. PS jacket and hook rack, including cover plates and hood. Fire-resistance rating B2. Silver.

Alternative

Isolation en tissu fibreux high-tech Enveloppe en PS équipée d'un support à crochets préinstallé, y compris rosettes et capot. Classe allemande de protection incendie B2. Couleur argent.

Alternativa

Isolamento in tessuto non tessuto high-tech. Mantello in PS e barra con ganci, rosette e calotta di copertura incluse. Classe di resistenza antincendio B2. Colore argento.

TopShell

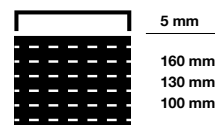

Pufferspeicher
Buffer storage tanks
Ballon tampon
Accumulatori tampone
PSR 500 – 5000

	Verwendung Usage Utilisation Uso	500	600	800	1000	1050	1250	1500	1600	1950	2000	2500	3000	4000	5000
TopShell 100	Wärmeverlust [kWh/24h] Heat losses Pertes thermiques Perdita di calore	2.61	2.89	3.12	3.38	3.49	3.82	-	-	-	-	-	-	-	-
	ErP-Label ErP class Classe ErP Classe ErP	C	C	C	C	C	C	(D)	(D)	-	-	-	-	-	-
	Zulassung CH Approval Certification Omologazione	X	•	•	•	•	•	X	X	X	X	X	X	X	X
	Zulassung EU Approval Certification Omologazione	•	•	•	•	•	•	X	X	•	•	•	•	•	•
	A $\overline{\downarrow}$ [mm]	1680	1700	1740	2090	2050	2060	2200	1900	2010	2420	2330	2770	2885	2920
	C Ø [mm]	850	900	990	990	1050	1150	1200	1300	1450	1300	1450	1450	1600	1800
	Art. Nr. 300106... Part no. Réf. Art.n.	0501	0601	0801	1001	1051	1251	1501*	1601*	1951	2001	2501	3001	4001	5001
TopShell 130	Wärmeverlust [kWh/24h] Heat losses Pertes thermiques Perdita di calore	-	-	-	-	-	-	4.0	4.08	-	-	-	-	-	-
	ErP-Label ErP class Classe ErP Classe ErP	-	-	-	-	-	-	C	C	-	-	-	-	-	-
	Zulassung CH Approval Certification Omologazione	X	•	•	•	•	•	•	•	X	X	X	X	X	X
	Zulassung EU Approval Certification Omologazione	•	•	•	•	•	•	•	•	•	•	•	•	•	•
	A $\overline{\downarrow}$ [mm]	1710	1730	1770	2120	2080	2090	2230	1930	2040	2450	2360	2800	2915	2950
	C Ø [mm]	910	960	1050	1050	1110	1210	1260	1360	1510	1360	1510	1510	1660	1860
	Art. Nr. 300106... Part no. Réf. Art.n.	0502*	0602*	0802*	1002*	1052*	1252*	1502	1602	1952*	2002*	2502*	3002*	4002*	5002*
TopShell 160	Wärmeverlust [kWh/24h] Heat losses Pertes thermiques Perdita di calore	-	-	-	-	-	-	-	-	-	-	-	-	-	-
	ErP-Label ErP class Classe ErP Classe ErP	-	-	-	-	-	-	-	-	-	-	-	-	-	-
	Zulassung CH Approval Certification Omologazione	X	•	•	•	•	•	•	•	•	•	•	•	•	•
	Zulassung EU Approval Certification Omologazione	•	•	•	•	•	•	•	•	•	•	•	•	•	•
	A $\overline{\downarrow}$ [mm]	1710	1760	1800	2150	2110	2120	2260	1960	2070	2480	2390	2830	2945	2980
	C Ø [mm]	970	1020	1110	1110	1170	1270	1320	1420	1570	1420	1570	1570	1720	1920
	Art. Nr. 300106... Part no. Réf. Art.n.	0503*	0603*	0803*	1003*	1053*	1253*	1503*	1603*	1953	2003	2503	3003	4003	5003

* Keine Lagerware. Lieferzeit 4–6 Wochen

Not in stock. Delivery time 4–6 weeks | Marchandise non stockée. Délai: 4 à 6 semaines | Merce non a magazzino. Tempistiche di consegna 4–6 settimane

Nicht zugelassen | None approved | Non agréée | Non omologato

Zugelassen (Empfohlene Isolierung)
Approved (Recommended insulation) | Agréée (Isolation recommandée) | Omologato (Isolamento consigliato)

Zugelassen (oberhalb Mindestanforderung)
Approved (Exceeds minimum requirements) | Agréée (Supérieure aux exigences minimales requises) | Omologato (Requisito minimo superiore)

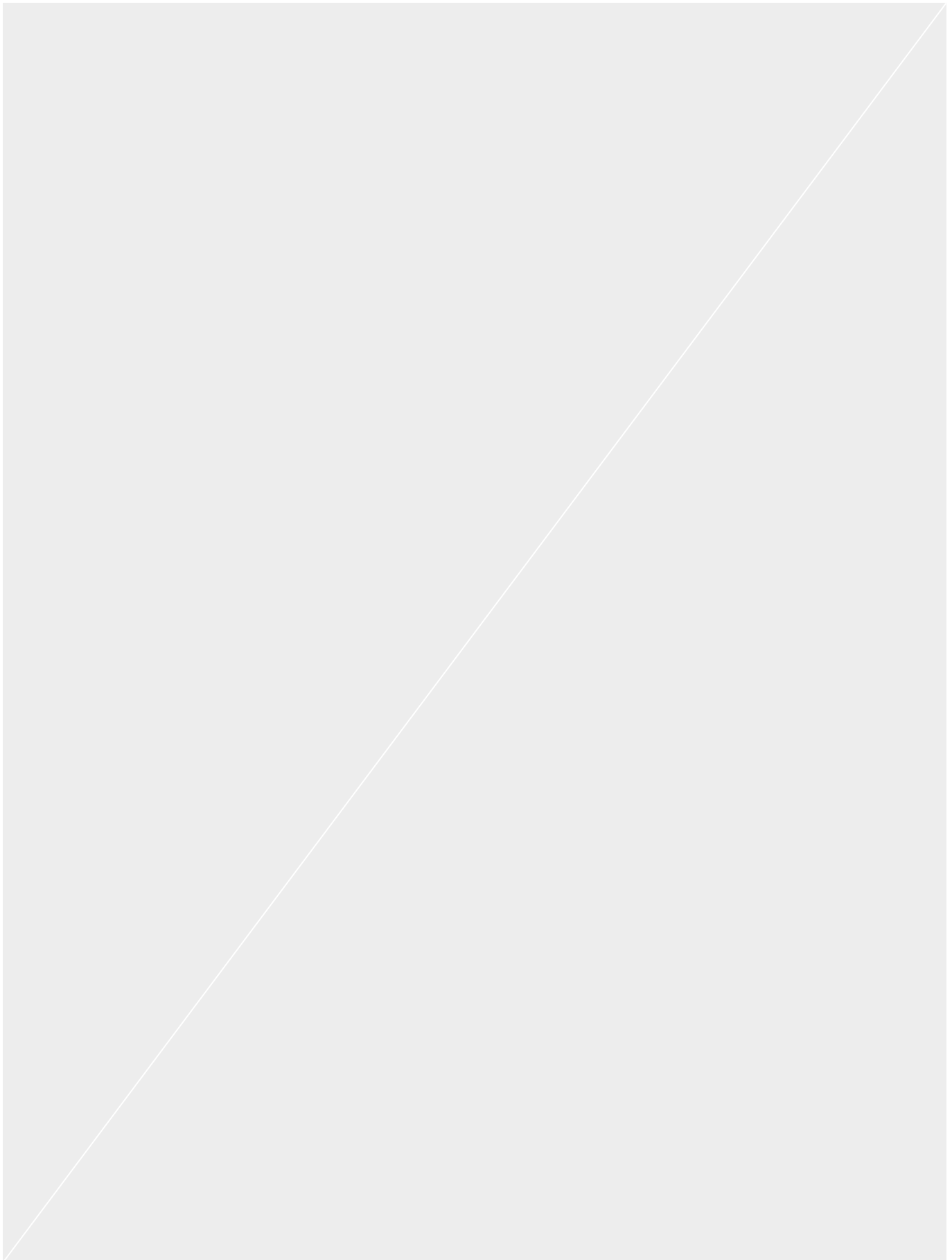

Pufferspeicher
Buffer storage tanks
Ballon tampon
Accumulatori tampone
PSR 500 – 5000



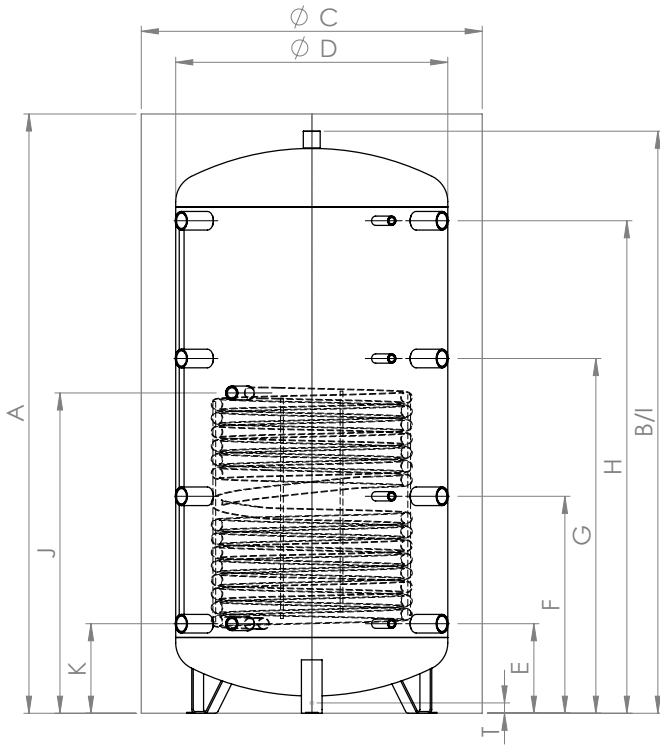



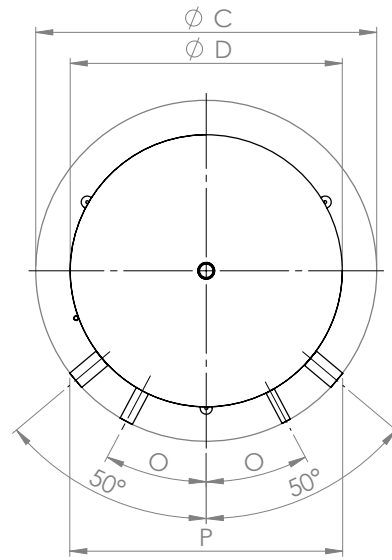





500 – 5000



500 – 5000



500 – 5000

Verwendung Usage Utilisation Uso		Dimension Dimension Dimensione	500	600	800	1000	1050	1250	1500	1600	1950	2000	2500	3000	4000	5000
Inhalt Capacity Contenance Contenuto		l	480	560	718	887	996	1266	1500	1555	2005	2021	2304	2852	3759	5003
Glattrohrwärmetauscher Heating coil Échangeurs de chaleur Serpentino		m ²	2.3	1.8	2.8	3.1	3.1	3.1	3.6	3.7	3.0	4.2	4.2	4.2	5.4	6.1
		l	15.1	11.8	18.3	20.3	20.3	20.3	23.6	24.3	19.7	27.5	27.5	27.5	35.3	39.9
Kippmass Tilted dimension Cote de basculement Altezza in raddrizzamento		mm	1665	1690	1740	2085	2020	2070	2195	1930	2060	2420	2395	2780	2935	3035
P	Einbringmass Delivery dimensions Cote de mise en place Ingombro	100 mm	690	740	800	800	850	950	1000	1100	1250	1100	1250	1250	1400	1600
		130 mm	740	780	840	840	890	970	1010	1100	1250	1100	1250	1250	1400	1600
		160 mm	780	820	890	890	930	1100	1050	1130	1250	1130	1250	1250	1400	1600
B	Höhe ohne Isolierung Height without insulation Hauteur sans isolation Altezza senza isolamento	mm	1630	1650	1690	2040	2000	2010	2150	1950	2060	2370	2280	2720	2835	2870
D	Ø ohne Isolierung without insulation sans isolation senza isolamento	mm	650	700	790	790	850	950	1000	1100	1250	1100	1250	1250	1400	1600
E*	Anschluss 1 Connection Raccord Collegamento	 - mm	220	230	260	310	310	310	380	320	495	320	535	380	505	400
		G"	1 1/2"	1 1/2"	1 1/2"	1 1/2"	1 1/2"	1 1/2"	1 1/2"	1 1/2"	2"	1 1/2"	2"	2"	2"	2"
		 - G"	1/2"	1/2"	1/2"	1/2"	1/2"	1/2"	1/2"	1/2"	1/2"	1/2"	1/2"	1/2"	1/2"	1/2"
F*	Anschluss 2 Connection Raccord Collegamento	 - mm	620	610	630	745	745	745	825	740	875	900	975	1020	1110	1100
		G"	1 1/2"	1 1/2"	1 1/2"	1 1/2"	1 1/2"	1 1/2"	1 1/2"	1 1/2"	2"	1 1/2"	2"	2"	2"	2"
		 - G"	1/2"	1/2"	1/2"	1/2"	1/2"	1/2"	1/2"	1/2"	1/2"	1/2"	1/2"	1/2"	1/2"	1/2"
G*	Anschluss 3 Connection Raccord Collegamento	 - mm	1010	990	1030	1250	1250	1250	1350	1150	1255	1490	1415	1680	1860	1810
		G"	1 1/2"	1 1/2"	1 1/2"	1 1/2"	1 1/2"	1 1/2"	1 1/2"	1 1/2"	2"	1 1/2"	2"	2"	2"	2"
		 - G"	1/2"	1/2"	1/2"	1/2"	1/2"	1/2"	1/2"	1/2"	1/2"	1/2"	1/2"	1/2"	1/2"	1/2"
H*	Anschluss 4 Connection Raccord Collegamento	 - mm	1390	1380	1430	1710	1710	1710	1760	1570	1635	2020	1855	2330	2410	2520
		G"	1 1/2"	1 1/2"	1 1/2"	1 1/2"	1 1/2"	1 1/2"	1 1/2"	1 1/2"	2"	1 1/2"	2"	2"	2"	2"
		 - G"	1/2"	1/2"	1/2"	1/2"	1/2"	1/2"	1/2"	1/2"	1/2"	1/2"	1/2"	1/2"	1/2"	1/2"
I	Anschluss oben Connection above Raccord du haut Collegamento superiore	 - mm	1630	1650	1690	2040	2050	2010	2150	1900	2010	2370	2280	2720	2835	2870
		G"	1 1/4"	1 1/4"	1 1/4"	1 1/4"	1 1/4"	1 1/4"	1 1/4"	1 1/4"	1 1/4"	1 1/4"	1 1/4"	1 1/4"	1 1/4"	1 1/4"
J	VL Glattrohrwärmetauscher Heating coil Échangeurs de chaleur Serpentino	 - mm	1120	790	930	1030	990	1015	1180	970	1025	1120	1250	1430	1555	1580
		G"	1"	1"	1"	1"	1"	1"	1"	1"	1"	1"	1"	1"	1"	1"
K	RL Glattrohrwärmetauscher Heating coil Échangeurs de chaleur Serpentino	 - mm	220	250	260	310	310	300	380	320	495	320	535	480	505	580
		G"	1"	1"	1"	1"	1"	1"	1"	1"	1"	1"	1"	1"	1"	1"
T	Bodenmuffe Ground fitting Manchon de fond Manicotto a pavimento	 - mm	-	-	-	-	-	-	-	-	110	-	110	100	75	50
		G"	-	-	-	-	-	-	-	-	1 1/4"	-	1 1/4"	1 1/4"	1 1/4"	1 1/4"
O	Anordnung Fühler Positioning sensor Disposition sonde Disposizione sensore	°	23.5	28.0	28.0	28.0	29.8	32.0	33.0	34.5	36.0	34.5	36.0	36.0	37.5	39.0
Gewicht Weight Poids Peso		kg	113	111	138	157	161	204	222	227	256	264	303	350	446	523
Art.Nr. 100 mm 200105... Part no. Réf. Art.n.			0501	0601	0801	1001	1051	1251	1501	1601	1951	2001	2501	3001	4001	5001
Art.Nr. 130 mm 200105... Part no. Réf. Art.n.			0502	0602	0802	1002	1052	1252	1502	1602	1952	2002	2502	3002	4002	5002
Art.Nr. 160 mm 200105... Part no. Réf. Art.n.			0503	0603	0803	1003	1053	1253	1503	1603	1953	2003	2503	3003	4003	5003
Elektroheizung zum Einschrauben* Screw-in Immersion heater* Résistances à visser* Resistenza elettrica da avvitare*		bis kW to à a	6.0	7.5	9.0	9.0	9.0	9.0	9.0	9.0	9.0	9.0	9.0	9.0	9.0	9.0

*Einbaumöglichkeit: 1 x Elektroheizung zum Einschrauben
Installation option: 1 x Screw-in Immersion heater | Option d'installation: 1 x Résistances à visser | Opzione di installazione: 1 x Resistenza elettrica da avvitare