

**Kombispeicher**  
**Combination storage tanks**  
**Ballon mixte**  
**Serbatoi di accumulo combinati**  
**PBNR/E 600 – 1500**

**Emailliert**  
 Enamelled | Émaillés | Smaltato

**DIN**

**EN 12897**  
**EnEV 730.02**  
**ErP 812/2013**  
**ErP 814/2013**  
**DIN 4753**

**CE**

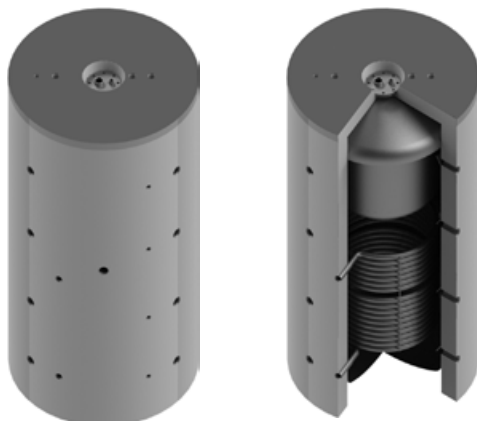

**Bauart**

**Design | Structure | Struttura**

Die Speicher werden aus hochwertigem Stahl nach EN 10025 gefertigt.  
 Die Speicher werden nach EN 12897:2014 dimensioniert, gefertigt und zertifiziert.

**EN** The storage tanks are made from high quality steel in accordance with EN 10025.  
 The storage tanks are designed, manufactured and certified in accordance with EN 12897:2014.

**FR** Les ballons sont fabriqués en acier de grande qualité selon la norme EN 10025.  
 Les ballons sont dimensionnés, fabriqués et certifiés selon la norme EN 12897:2014.

**IT** Gli accumulatori sono realizzati in acciaio pregiato secondo la norma EN 10025.  
 Gli accumulatori sono dimensionati, costruiti e certificati secondo la norma EN 12897:2014.

**Lieferumfang**

**Delivery | Livraison | Consegna**

	mm		Art. Nr.
<b>Bedienungsanleitung</b> Operation manual   Mode d'emploi   Istruzioni per l'uso		1 x	
<b>Thermometer mit Tauchhülse</b> Thermometer with immersion sleeve   Thermomètre avec manchon d'immersion   Termometro con manicotto ad immersione	100	1 x	6001150100
<b>Tauchhülse</b> Immersion sleeve   Manchon d'immersion   Manicotto ad immersione	500	1 x	6001180511
<b>Magnesium Schutzanode</b> Magnesium protective anode   Anode protectrice de magnésium   Anodo protettivo in magnesio	520	1 x	6001140520

**Schutz vor Korrosion****Anti-corrosion protection | Protection contre la corrosion | Protezione anticorrosiva**

Die Trinkwasserspeicher haben eine doppelt gebrannte Zweischicht-Emaillierung nach DIN 4753. Grosszügige Magnesium Schutzanode nach DIN 4753-3. Die Pufferspeicher sind innen unbehandelt. Die Kombispeicher sind aussen mit einem Antikorrosionslack lackiert.

**EN** Dual-fired two-layer enamelling in accordance with DIN 4753. Generous magnesium protection anode in accordance with DIN 4753-3. Storage tanks with separate insulation are coated on the exterior with an anticorrosion paint.

**FR** Émaillage bi-couche à double cuisson conforme à la norme DIN 4753. Anode de protection de belle taille en magnésium conforme à la norme DIN 4753-3. Les réservoirs avec isolation séparée sont recouverts à l'extérieur d'une laque anticorrosion.

**IT** Smaltatura a doppia mano secondo DIN 4753. Anodo protettivo di magnesio in grande quantità secondo DIN 4753-3. Gli accumulatori con isolamento separato sono verniciati esternamente con smalto resistente alla corrosione.

**Wärmetauscher****Heat exchanger | Échangeur de chaleur | Scambiatore di calore**

Die Oberfläche des Trinkwasserspeichers dient als Wärmetauscher.  
Ein eingeschweisster grossflächiger Wärmetauscher.

**EN** The surface of the domestic hot water storage tank acts as a heat exchanger.  
One welded large-surface heat exchanger.

**FR** La surface du ballon d'eau sanitaire placé à l'intérieur fait office d'échangeur de chaleur.  
Un échangeur de chaleur grande surface soudé.

**IT** La superficie dell'accumulatore d'acqua potabile funge da scambiatore di calore.  
Uno scambiatore di calore saldato di grande superficie.

**Isolierung****Insulation | Isolation | Isolamento****TopShell**

Isolierung aus Hightech Faservlies. Skaimantel mit Reissverschluss, inklusive Rosetten und Abdeckhaube.  
Brandschutzklasse B2. Silber. Lose geliefert.

**Variante**

Isolierung aus Hightech Faservlies. PS-Mantel und Hakenleiste, inklusive Rosetten und Abdeckhaube.  
Brandschutzklasse B2. Farbe Silber.

**EN TopShell**

Insulation made of high-tech fibre fleece. Skai jacket with zip, including cover plates and hood. Fire-resistance rating B2. Silver. Supplied loose.

**FR TopShell**

Isolation en tissu fibreux high-tech Enveloppe en skai avec fermeture à glissière, y compris rosettes et capot. Classe allemande de protection incendie B2. Argent. Livrée non montée.

**IT TopShell**

Isolamento in tessuto non tessuto high-tech. Mantello in skai pre-assemblato con cerniera, dotato di rosette e calotta di copertura. Classe di resistenza antincendio B2. Argento. Consegna sfusa.

**Alternative**

Insulation made of high-tech fibre fleece. PS jacket and hook rack, including cover plates and hood. Fire-resistance rating B2. Silver.

**Alternative**

Isolation en tissu fibreux high-tech Enveloppe en PS équipée d'un support à crochets préinstallé, y compris rosettes et capot. Classe allemande de protection incendie B2. Couleur argent.

**Alternativa**

Isolamento in tessuto non tessuto high-tech. Mantello in PS e barra con ganci, rosette e calotta di copertura incluse. Classe di resistenza antincendio B2. Colore argento.

TopShell

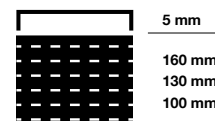

**Kombispeicher**  
**Combination storage tanks**  
**Ballon mixte**  
**Serbatoi di accumulo combinati**  
**PBNR/E 600 – 1500**

**Emailliert**  
 Enamelled | Émaillés | Smaltato

Typ PBNR/E		600/150	800/200	1000/200	1500/230
Inhalt Heizwasser Hot water capacity   Contenance de l'eau de chauffage   Contenuto acqua calda	l	391	493	653	1219
Inhalt Brauchwasser Service water capacity   Contenance de l'eau sanitaire   Contenuto acqua per uso domestico	l	150	204	204	247
Ø mit Isolierung with insulation   avec isolation   con isolamento	mm	900	990	990	1260
Ø ohne Isolierung without insulation   sans isolation   senza isolamento	mm	700	790	790	1000
Höhe mit Isolierung Height with insulation   Hauteur avec isolation   Altezza con isolamento	mm	1700	1740	2090	2230
Kippmass Tilted dimension   Cote de basculement   Altezza in raddrizzamento	mm	1780	1850	2175	2315
Betriebsdruck Trinkwasserspeicher Domestic hot water tank operating pressure   Pression de service de la ballon ECS   Pressione d'esercizio bollitore	bar	6	6	6	6
Betriebsdruck Puffer Buffer tank operating pressure   Pression de service du ballon de stockage   Pressione d'esercizio tampone	bar	3	3	3	3
Prüfdruck Puffer Buffer tank test pressure   Pression test Ballon de stockage   Pressione di collaudo tampone	bar	4.5	4.5	4.5	4.5
max. Betriebstemperatur max. operating temperature   Temp. de service max.   Temperatura max. d'esercizio	°C	95	95	95	95
Gewicht Weight   Poids   Peso	kg	161	187	218	297
Art.Nr. 200202... Part no.   Réf.   Art.n.		0600	0800	1000	1500
<b>Isolierung</b> Insulation   Isolation   Isolamento		<b>TopShell 100</b>			<b>TopShell 130</b>
Wärmeverlust Heat losses   Pertes thermiques   Perdita di calore	kWh/24h	2.89	3.12	3.38	4.0
ErP-Klasse ErP class   Classe ErP   Classe ErP		C	C	C	C
Gewicht Weight   Poids   Peso	kg	19	25	32	39
Art.Nr. 300112... Part no.   Réf.   Art.n.		0601	0801	1001	1502



Typ PBNF/E		600/150		800/200		1000/200		1500/230	
Glattrohrwärmetauscher Heating coil   Échangeurs de chaleur   Serpentino	m <sup>2</sup>	1.8		2.0		3.1		3.6	
Inhalt Glattrohrwärmetauscher Heating coil capacity   Contenance échangeurs de chaleur   Contenuto serpentinos de chaleur	l	11.8		13.3		20.5		23.3	
Puffertemperatur Buffer tank temperature   Température du ballon   Temperatura tampone	°C	55	80	55	80	55	80	55	80
Warmwasserdauerleistung Hot water continuous output   Régime permanent eau chaude   Potenza continua acqua calda 10°C / 45°C / 80°C	l / h	138	354	172	443	172	443	184	473
max. Warmwasserdauerleistung max. hot water continuous output   Régime permanent max. eau chaude   Potenza continua max. acqua calda	kW	5.6	14.4	7.0	18.0	7.0	18.0	7.5	19.2

**Kombispeicher**  
**Combination storage tanks**  
**Ballon mixte**  
**Serbatoi di accumulo combinati**  
**PBNR/E 600 – 1500**

**Emailliert**  
Enamelled | Émaillés | Smaltato

600 – 1500

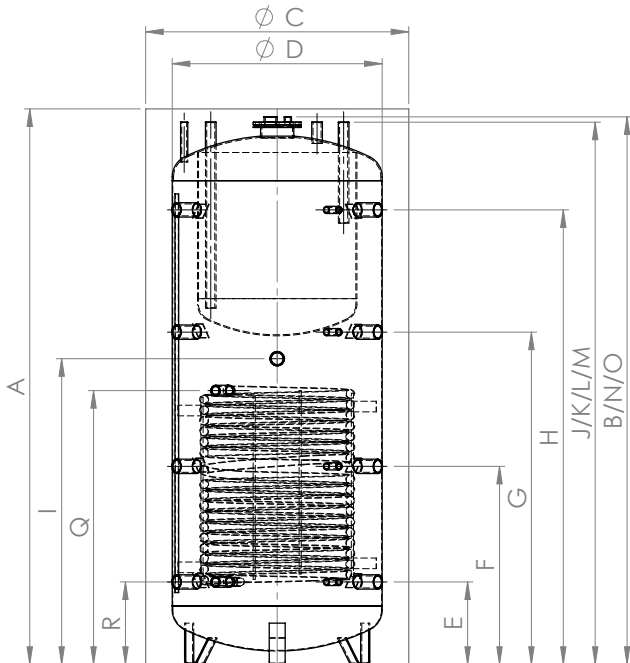

600 – 1500

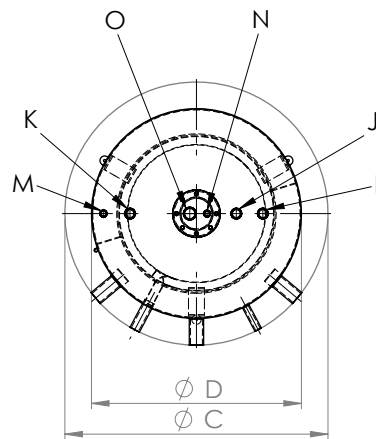

600 – 1500



	Verwendung Usage Utilisation Uso	Dimension Dimension Dimensione	600/150	800/200	1000/200	1500/230
A	Höhe Height   Hauteur   Altezza	○ – mm	1700	1740	2090	2230
B		○ – mm	1670	1710	2060	2170
C	∅	● – mm	900	990	990	1260
D		○ – mm	700	790	790	1000
E	Anschluss 1 Connection   Raccord   Collegamento	⇕ – mm	230	260	310	380
		G" – mm	1 ½"	1 ½"	1 ½"	1 ½"
		⊕ – G"	½"	½"	½"	½"
F	Anschluss 2 Connection   Raccord   Collegamento	⇕ – mm	610	630	745	825
		G" – mm	1 ½"	1 ½"	1 ½"	1 ½"
		⊕ – G"	½"	½"	½"	½"
G	Anschluss 3 Connection   Raccord   Collegamento	⇕ – mm	990	1030	1250	1350
		G" – mm	1 ½"	1 ½"	1 ½"	1 ½"
		⊕ – G"	½"	½"	½"	½"
H	Anschluss 4 Connection   Raccord   Collegamento	⇕ – mm	1380	1430	1710	1760
		G" – mm	1 ½"	1 ½"	1 ½"	1 ½"
		⊕ – G"	½"	½"	½"	½"
I	Anschluss Mitte / ESH Connection middle SIH   Raccord milieu   Collegamento centrale	⇕ – mm	850	800	1150	1250
		G" – mm	1 ½"	1 ½"	1 ½"	1 ½"
J	Warmwasser Hot water   Eau chaude   Acqua calda	⇕ – mm	1650	1690	2040	2150
		G" – mm	1"	1"	1"	1"
K	Kaltwasser Cold water   Eau froide   Acqua fredda	⇕ – mm	1650	1690	2040	2150
		G" – mm	1"	1"	1"	1"
L	Zirkulation Circulation   Circulation   Circolazione	⇕ – mm	1650	1690	2040	2150
		G" – mm	1"	1"	1"	1"
M	Entlüftung Vent   Purge   Sfiato	⇕ – mm	1650	1690	2040	2150
		G" – mm	½"	½"	½"	½"
N	Fühler Brauchwasser Service water sensor   Sonde eau industrielle   Sensore acqua per uso domestico	⇕ – mm	1670	1710	2060	2170
		G" – mm	½"	½"	½"	½"
O	Magnesiumanode Magnesium anode   Anode de magnésium   Anodo in magnesio	⇕ – mm	1670	1710	2060	2170
		G" – mm	1 ¼"	1 ¼"	1 ¼"	1 ¼"
P	Flansch Flange   Bride   Flangia	⇕ – mm	370	400	400	450
		∅ – mm	290/220	290/220	290/220	290/220
Q	VL Glattrohrwärmetauscher Heating coil   Échangeurs de chaleur   Serpentino	⇕ – mm	790	730	1030	1180
		G" – mm	1"	1"	1"	1"
R	RL Glattrohrwärmetauscher Heating coil   Échangeurs de chaleur   Serpentino	⇕ – mm	250	260	310	380
		G" – mm	1"	1"	1"	1"