

Frischwasserspeicher
Fresh water storage tank
Ballon d'eau fraiche
Accumulatori d'acqua dolce

JHS WP 800 – 1000 für Wärmepumpe | for heat pump | pour pompe à chaleur | per pompa di calore

DIN

EN 12897

EnEV 730.02

ErP 812/2013

ErP 814/2013

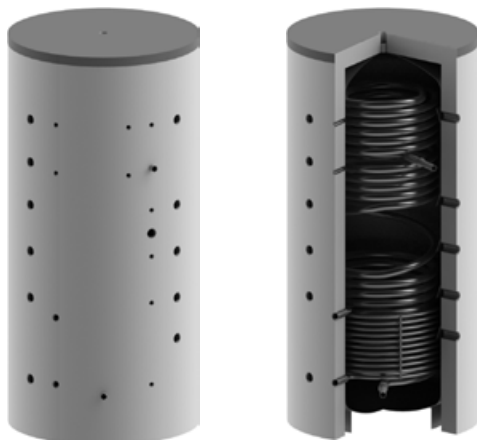

Bauart

Design | Structure | Struttura

Die Speicher werden aus hochwertigem Stahl nach EN 10025 gefertigt.

Die Wärmetauscher bestehen aus Edelstahl V4A. Die Speicher sind innen unbehandelt.

EN The storage tanks are made from high quality steel in accordance with EN 10025.

The heat exchanger is made from stainless steel (V4A).

The tanks are not treated on the inside.

FR Les ballons sont fabriqués en acier de grande qualité, selon la norme EN 10025.

Les échangeurs de chaleur sont en acier inoxydable au molybdène.

L'intérieur des ballons n'est pas traité.

IT Gli accumulatori sono realizzati in acciaio pregiato secondo la norma EN 10025.

Lo scambiatore di calore è realizzato in acciaio inossidabile V4A.

L'interno degli accumulatori non è trattato.

Lieferumfang

Delivery | Livraison | Consegna

Bedienungsanleitung

Operation manual | Mode d'emploi | Istruzioni per l'uso

1 x



Schutz vor Korrosion

Anti-corrosion protection | Protection contre la corrosion | Protezione anticorrosiva

Innen sind die Speicher unbehandelt. Aussen sind die Speicher mit einem Antikorrosionslack lackiert.
Der Wellrohrwärmetauscher ist aus hochwertigem Edelstahl V4A gefertigt.

EN The storage tanks are untreated on the interior. The storage tanks are externally coated with a corrosion-protection paint. The corrugated pipe heat exchanger is made of high-quality stainless steel V4A.

FR À l'intérieur, les réservoirs ne sont pas traités. À l'extérieur, les réservoirs sont recouverts d'une laque anticorrosion. L'échangeur thermique est fabriqué en acier inoxydable V4A haut de gamme.

IT L'interno degli accumulatori non è trattato. Gli accumulatori sono verniciati all'esterno con uno smalto resistente alla corrosione. Lo scambiatore di calore a tubi corrugati è realizzato in pregiato acciaio inossidabile V4A.

Wärmetauscher

Heat exchanger | Échangeur de chaleur | Scambiatore di calore

Heizungswasser: Ein eingeschweisster grossflächiger Wärmetauscher aus Stahlrohr.
Brauchwasser: Ein eingeschweisstes Wellrohr aus Edelstahl V4A.

EN Heating water: A welded large-surface heat exchanger made from a stainless steel pipe

Service water: A welded corrugated tube from stainless steel V4A.

FR Eau de chauffage: Un échangeur de chaleur grande surface soudé en tube d'acier.

Eau sanitaire: Un tube ondulé soudé en Acier inoxydable V4A au molybdène.

IT Acqua di riscaldamento: Uno scambiatore di calore saldato di grande superficie in tubo d'acciaio.

Acqua per uso domestico: Un tubo ondulato saldato in acciaio inossidabile V4A.

Isolierung

Insulation | Isolation | Isolamento

TopShell

Isolierung aus Hightech Faservlies. Skaimantel mit Reissverschluss, inklusive Rosetten und Abdeckhaube.
Brandschutzklasse B2. Silber. Lose geliefert.

Variante

Isolierung aus Hightech Faservlies. PS-Mantel und Hakenleiste, inklusive Rosetten und Abdeckhaube.
Brandschutzklasse B2. Farbe Silber.

EN TopShell

Insulation made of high-tech fibre fleece. Skai jacket with zip, including cover plates and hood. Fire-resistance rating B2. Silver. Supplied loose.

FR TopShell

Isolation en tissu fibreux high-tech Enveloppe en skai avec fermeture à glissière, y compris rosettes et capot. Classe allemande de protection incendie B2. Argent. Livrée non montée.

IT TopShell

Isolamento in tessuto non tessuto high-tech. Mantello in skai pre-assemblato con cerniera, dotato di rosette e calotta di copertura. Classe di resistenza antincendio B2. Argento. Consegna sfusa.

Alternative

Insulation made of high-tech fibre fleece. PS jacket and hook rack, including cover plates and hood. Fire-resistance rating B2. Silver.

Alternative

Isolation en tissu fibreux high-tech Enveloppe en PS équipée d'un support à crochets préinstallé, y compris rosettes et capot. Classe allemande de protection incendie B2. Couleur argent.

Alternativa

Isolamento in tessuto non tessuto high-tech. Mantello in PS e barra con ganci, rosette e calotta di copertura incluse. Classe di resistenza antincendio B2. Colore argento.

TopShell

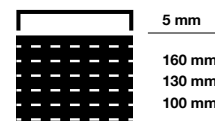

5 mm

160 mm

130 mm

100 mm

Frischwasserspeicher
Fresh water storage tank
Ballon d'eau fraîche
Accumulatori d'acqua dolce

JHS WP 800 – 1000 für Wärmepumpe | for heat pump | pour pompe à chaleur | per pompa di calore

Typ JHSWP		800	1000
Bruttoinhalt Gross capacity Contenance brute Contenuto lordo	l	718	887
Nettoinhalt Net capacity Contenance nette Contenuto netto	l	655	814
Ø mit Isolierung with insulation avec isolation con isolamento	mm	990	990
Ø ohne Isolierung without insulation sans isolation senza isolamento	mm	790	790
Höhe mit Isolierung Height with insulation Hauteur avec isolation Altezza con isolamento	mm	1740	2090
Kippmass Tilted dimension Cote de basculement Altezza in raddrizzamento	mm	1740	2085
Betriebsdruck Heizung Heater operating pressure Pression de service du chauffage Pressione d'esercizio riscaldamento	bar	3	3
Betriebsdruck Wasser Water operating pressure Pression de service de l'eau Pressione d'esercizio acqua	bar	6	6
max. Betriebstemperatur max. operating temperature Temp. de service max. Temperatura max. d'esercizio	°C	95	95
Gewicht Weight Poids Peso	kg	225	261
Art.Nr. 200208... Part no. Réf. Art.n.		0800	1000
Isolierung Insulation Isolation Isolamento		TopShell 100	
Wärmeverlust Heat losses Pertes thermiques Perdita di calore	kWh/24h	3.12	3.38
ErP-Klasse ErP class Classe ErP Classe ErP		C	C
Gewicht Weight Poids Peso	kg	23	30
Art.Nr. 300114... Part no. Réf. Art.n.		0801	1001



Typ JHSWP		800		1000	
Glattrohrwärmetauscher unten Bottom heating coil Échangeurs de chaleur bas Serpentino inferiore	m ²	2.5		2.5	
Inhalt Glattrohrwärmetauscher Heating coil capacity Contenance échangeurs de chaleur Contenuto serpentino	l	11.6		11.6	
Heizfläche Edelstahlwellrohr Heating surface stainless steel corrugated pipe Surface de chauffe du tube ondulé en acier inoxydable Superficie riscaldante tubo ondulato	m ²	9.8		9.8	
Inhalt Edelstahlwellrohr Stainless steel corrugated pipe capacity Contenance du tube ondulé en acier inoxydable Contenuto tubo ondulato	l	51.0		51.0	
Puffertemperatur Buffer tank temperature Température du ballon Temperatura tampone	°C	60	80	60	80
Warmwasserdauerleistung Hot water continuous output Régime continu eau chaude Potenza continua acqua calda 10°C / 45°C / 80°C	l / min	13.5	22.6	13.5	22.6
max. Warmwasserdauerleistung Max. hot water continuous output Régime continu maxi eau chaude Potenza continua acqua calda max.	kW	32	55	32	55

Frischwasserspeicher
Fresh water storage tank
Ballon d'eau fraîche

Accumulatori d'acqua dolce

JHS WP 800 – 1000 für Wärmepumpe | for heat pump | pour pompe à chaleur | per pompa di calore

800 – 1000

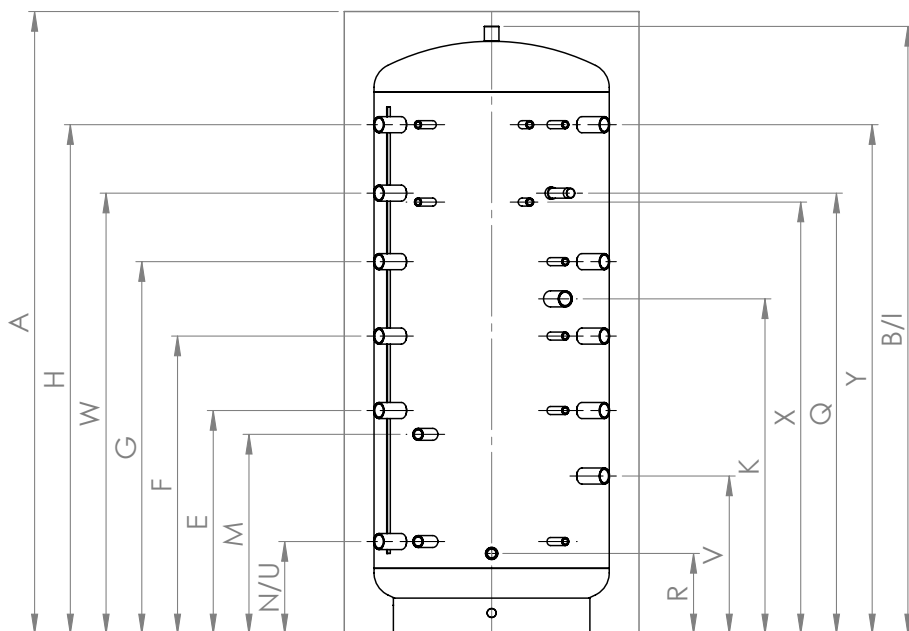

800 – 1000

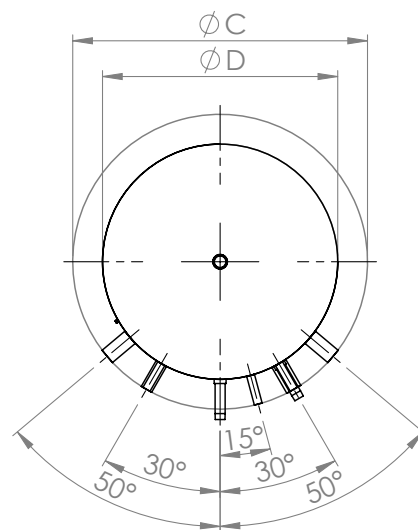

800 – 1000



	Verwendung Usage Utilisation Uso	Dimension Dimension Dimension Dimensione	800	1000
A	Höhe	– mm	1760	2090
B	Height Hauteur Altezza	– mm	1710	2040
C	∅	– mm	990	990
D		– mm	790	790
E	Anschluss 1 Connection Raccord Collegamento	– mm	630	750
		G" – mm	1 ½"	1 ½"
		– G"	½"	½"
F	Anschluss 2 Connection Raccord Collegamento	– mm	790	1000
		G" – mm	1 ½"	1 ½"
		– G"	½"	½"
G	Anschluss 3 Connection Raccord Collegamento	– mm	1030	1250
		G" – mm	1 ½"	1 ½"
		– G"	½"	½"
H	Anschluss 4 Connection Raccord Collegamento	– mm	1430	1710
		G" – mm	1 ½"	1 ½"
		– G"	½"	½"
I	Anschluss oben Connection above Raccord du haut Collegamento superiore	– mm	1710	2040
		G" – mm	1 ¼"	1 ¼"
K	Elektroheizung zum Einschrauben* Screw-in Immersion heater* Résistances à visser* Resistenza elettrica da avvitare*	– mm	915	1125
		G" – mm	1 ½"	1 ½"
		– °	30°	30°
M	VL Glattröhrwärmetauscher unten Bottom heating coil Échangeurs de chaleur bas Serpentino inferiore	– mm	690	670
		G" – mm	1"	1"
		– °	30°	30°
N	RL Glattröhrwärmetauscher unten Bottom heating coil Échangeurs de chaleur bas Serpentino inferiore	– mm	330	310
		G" – mm	1"	1"
		– °	30°	30°
Q	Edelstahlwellrohr Warmwasser Hot water stainless steel corrugated pipe Tube ondulé en acier inoxydable eau chaude Scambiatore di calore con tubo ondulato in acciaio inossidabile	– mm	1450	1770
		G" – mm	1"	1"
		– °	30°	30°
R	Edelstahlwellrohr Kaltwasser Cold water stainless steel corrugated pipe Tube ondulé en acier inoxydable eau froide Tubo ondulato acqua fredda	– mm	260	270
		G" – mm	1"	1"
		– °	0°	0°
U	Anschluss 5 Connection above Raccord du haut Collegamento superiore	– mm	260	310
		G" – mm	1 ½"	1 ½"
		– G"	½"	½"
V	Anschluss 6 Connection above Raccord du haut Collegamento superiore	– mm	430	530
		G" – mm	1 ½"	1 ½"
W	Anschluss 7 Connection above Raccord du haut Collegamento superiore	– mm	1240	1480
		G" – mm	1 ½"	1 ½"
X	Blindmuffe Connecting element Manchon borgne Manicotto cieco	– mm	1170	1450
		G" – mm	½"	½"
		– °	30° / 15°	30° / 15°
Y	Blindmuffe Connecting element Manchon borgne Manicotto cieco	– mm	1430	1710
		G" – mm	½"	½"
		– °	30° / 15°	30° / 15°

*Einbaumöglichkeit: 1 x Elektroheizung zum Einschrauben
Installation option: 1 x Screw-in Immersion heater | Option d'installation: 1 x Résistances à visser | Opzione di installazione: 1 x Resistenza elettrica da avvitare